

## Imperceptible Data Embedding in Sharply-Contrasted Binary Images

Anthony T.S. Ho, Niladri B. Puhan, A. Makur, P. Marziliano, Y.L. Guan

School of Electrical and Electronic Engineering  
Nanyang Technological University, Singapore  
E-mail: ETSHO @ ntu.edu.sg

*Abstract: Data embedding in sharply-contrasted binary images like text, drawing, signature and cartoon is a challenging issue due to simple pixel statistics in such images. Arbitrary modification to the pixels can be visually perceptible in the process of data embedding. The use of a valid perceptual model is important to minimize the effect of such visual distortion in binary images. In this paper, a novel perceptual model is used to embed significant amount of information such that the original and the marked images before and after data embedding process are perceptually similar. In our model, the distortion that occurs after flipping a pixel is estimated on the curvature-weighted distance difference (CWDD) measure between two contour segments.*

### 1. Introduction

The protection of ownership and the prevention of unauthorized tampering of multimedia data have become important topics in recent years. A variety of digital watermarking and data hiding techniques have been developed for such purposes [1]. In the case of natural images, imperceptible watermarking is possible due to the perceptual tolerance of human visual system [2]. For color and gray-scale images, perturbing pixel values by a small amount is generally unnoticeable under normal viewing conditions. However for binary images in which the pixels take on only two values 0 and 1, data embedding without causing visible artifacts becomes more difficult. The present work involves the use of a new perceptual model for data embedding in case of binary images.

Low *et al* [3] proposed robust data hiding methods in formatted document images based on imperceptible line and word shifting. Their methods were applied to embed information in text images for bulk electronic publications. In the line shifting method the embedded data is more robust to photocopying, scanning and printing process than by word shifting method. Koch and Zhao [4] proposed a data hiding algorithm in which a data bit '1' is embedded if the percentage of white pixels was greater than a given threshold, and a data bit '0' is embedded if the percentage of white pixels was less than another given threshold. Wu *et al* [5] hid data in a binary image using a hierarchical model in which human perception was taken into consideration. Distortion that occurred due to flipping of a pixel was measured by considering the change in smoothness and connectivity. In an 8x8 block, modifying the total

number of black pixels to be either odd or even embeds data bits. Mei *et al* modified an eight-connected boundary of a connected component for data hiding [6]. A set of pairs of five-pixel long boundary patterns have been identified for embedding data. One of the patterns in a pair required deletion of the center foreground pixel, whereas the other required the addition of a foreground pixel. This property allowed for blind detection of watermarking.

In section 2, we shall describe a novel perceptual model which enables us to hide significant amount of information in binary images. The implementation procedure is described in Section 3. The results will be presented in Section 4 and finally some conclusions are given in Section 5.

### 2. Proposed Perceptual Model

*Contour segment:* A contour segment with a set of  $n$  pixels  $\{p_i\}$ ,  $i = 0, 1, \dots, n-1$  can be represented by  $(n-1)$  chain codes  $\{c_i\}$ ,  $i = 1, 2, \dots, n-1$ , where  $c_i$  is the direction from pixel  $p_{i-1}$  to  $p_i$ .

To calculate the distortion for a pixel to be flipped, the 'original contour segment' and the 'watermarked contour segment' passing through this pixel is extracted. Both the contour segments are represented by 8-directional chain codes. Using the chain code  $c_i$ , the Euclidean distance  $d_i$  between two pixels  $p_{i-1}$  and  $p_i$  can be easily determined. The curvature value  $\alpha_{p_i}$  at pixel  $p_i$  is 0 for  $i = 0$  and  $i = n-1$ . For  $i = 1, \dots, n-2$ ,  $\alpha_{p_i}$  is computed from the chain codes  $c_i$  and  $c_{i+1}$  as:

$$\alpha_{p_i} = \begin{cases} \beta & \beta \leq 180^\circ \\ (360^\circ - \beta) & \text{otherwise} \end{cases} \quad (1)$$

$$\text{where } \beta = |c_{i+1} - c_i| \times 45^\circ \quad (2)$$

After obtaining the curvature value at each pixel, a weight sequence  $\{w_i\}$ ,  $i = 0, 1, \dots, n-1$  is experimentally defined in Eq. 3 such that  $w_i$  is chosen to be monotonic to  $\alpha_{p_i}$ .

$$w_i = \begin{cases} 1 & \alpha_{p_i} = 0^\circ \\ 1.5 & \alpha_{p_i} = 45^\circ \\ 3 & \alpha_{p_i} = 90^\circ \\ 4.5 & \alpha_{p_i} = 135^\circ \\ 6 & \alpha_{p_i} = 180^\circ \end{cases} \quad (3)$$

The curvature-weighted distance ( $D_\alpha$ ) of a contour segment is then defined by

$$D_\alpha = \sum_{i=1}^{n-1} w_{i-1} \cdot d_i \quad (4)$$

Let  $D_\alpha^{original}$  and  $D_\alpha^{watermarked}$  be the curvature-weighted distances of the original and watermarked contour segments, respectively. The *CWDD* measure for the flipped pixel is then given by:

$$CWDD = |D_\alpha^{original} - D_\alpha^{watermarked}| \quad (5)$$

### 3. Implementation

Figure 1 shows the block diagram of the implementation process. The first step in the implementation process is 'connected component labeling'. This block extracts all the connected components like the characters and other symbols in a binary image. The contour tracing method proposed by Pavlidis in [7] is then used to obtain the outer and all inner contours for each connected component. The contour traced by this algorithm is 8-connected, i.e. each pixel included in the contour has at least one 4-connected neighbor pixel of opposite value. The total number of outer and inner contours ( $N_b$ ) is given by:

$$N_b = 1 + N_h = 1 + (1 - E_N) = 2 - E_N \quad (6)$$

The number of contours in a symbol or character increases if the Euler number is less for it. So the probability of having larger number of flippable pixels in a symbol or character increases with the reduction in the Euler number magnitude. As illustrated in Figure 1, the 'contour segment extraction' block outputs two contour segments at every pixel in each connected component. In case of a black contour pixel, the 'original contour segment' centered on it is obtained from the traced contours. After flipping the black pixel, and provided the connectivity is not changed, the 'modified contour segment' is then obtained by applying the contour tracing algorithm once again between the first and last pixel of the 'original contour segment'. For a white contour pixel, one of its 4-connected black neighbor pixels is chosen as the center pixel of the 'original contour segment'. The *CWDD* measure for the pixel is then computed from the two

contour segments by using Eq. (1) through Eq. (5). The connected components in which the number of the black pixels is less than a threshold are not considered for computing the *CWDD* measure.

### 4. Results

We consider three sample images from the category of signature, text and drawing images. In these images for each pixel the *CWDD* measure is computed. To minimize the visual distortion, we choose to flip the pixels which have *CWDD* measure within the range from 0 to 1. Flipping a black to white pixel embeds a "0" and flipping a white to black pixel embeds a "1" in the original image. The image is scanned row-by-row for flipping the suitable pixels sequentially. A minimum distance between the flipping pixels is maintained to avoid interference between them. In the detection process the original image is used, so the data embedding process is considered to be a "non-blind" approach. The flipping pixels are easily identified in a sequential manner and the embedded bits are extracted correctly. In the chosen original images 143 bits in signature, 1031 bits in text, and 455 bits in drawing could be embedded without any annoying visible distortion. Figures 2-4 illustrate the original and the embedded images of different categories and also the flipped pixel positions. To estimate the data embedding capacity in different images, subjective experiments shall be conducted to verify the model prediction.

### 5. Conclusion

In this paper, we introduced a new perceptual model for data embedding and watermarking applications in the binary images. In the model, the distortion that occurred after flipping a pixel was estimated on the *CWDD* measure between two contour segments. The two contour segments for a pixel were obtained by applying two preprocessing algorithms such as connected component labeling and contour tracing. For those pixels with *CWDD* measure in the range of [0, 1], the subjective distortion is less making them suitable for data embedding. Since significant number of no-distortion pixels can be identified for flipping, the proposed perceptual model is useful in exploring new techniques that can address the requirements of various applications efficiently and meaningfully. At present we are designing the embedding and blind detection method for fragile authentication of binary images.

### 6. References

- [1] F. Hartung and M. Kutter, "Multimedia Watermarking Techniques," *Proc. of the IEEE*, vol. 87, July 1999.

[2] C. Podilchuk, W. Zeng, "Image Adaptive Watermarking Using Visual Models", *IEEE Journal Selected Areas of Communications (JSAC)*, vol. 16, no. 4, May 1998.

[3] S. H. Low, N. F. Maxemchuk, and A. M. Lapone, "Document identification for copyright protection using centroid detection," *IEEE Trans. on Communication*, vol. 46, no. 3, March 1998, pp. 372-383.

[4] E. Koch, J. Zhao, "Embedding robust labels into images for copyright protection," *Proc. International Congress on Intellectual Property Rights for Specialized Information, Knowledge & New Technologies*, Vienna, Aug. 1995.

[5] M. Wu, E. Tang, and B. Liu, "Data hiding in digital binary images," *Proc. IEEE Int'l Conf. on Multimedia and Expo*, Jul 31-Aug 2, 2000, New York.

[6] Q. Mei, E. K. Wong, and N. Memon, "Data hiding in binary text documents," *SPIE Proc Security and Watermarking of Multimedia Contents III*, San Jose, CA, Jan. 2001.

[7] T. Pavlidis, "Algorithms for Graphics and Image Processing," Computer Science Press, Rockville, Maryland, 1982.

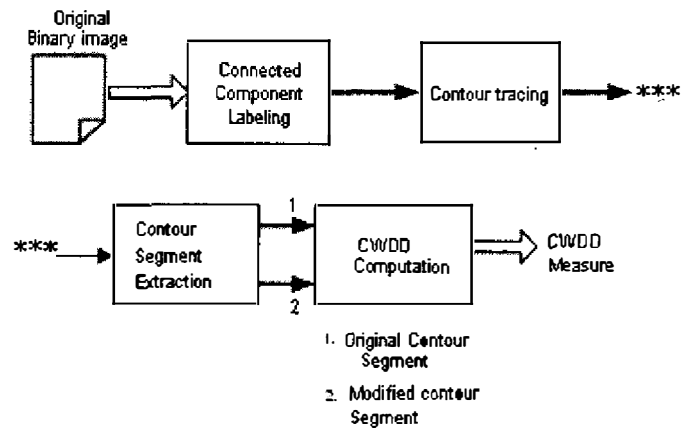

Figure 1: Block diagram of the implementation procedure for computing the CWDD measure.

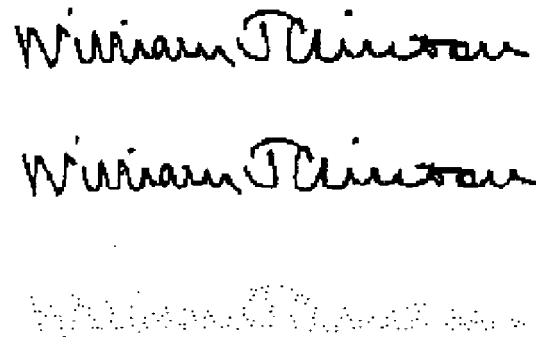

Figure 2: First image is the original signature image of size 49x325 pixels. Second image with 143 bits hidden in CWDD range [0, 1]. Third image shows the flipping pixel positions.

The recent development of various methods of modulation such as PCM and PPM which exchange bandwidth for signal-to-noise ratio has intensified the interest in a general theory of communication. A basis for such a theory is contained in the important papers of Nyquist and Hartley on this subject. In the present paper we will extend the theory to include a number of new factors, in particular the effect of noise in the channel, and the savings possible due to the statistical structure of the original message and due to the nature of the final destination of the information.

The recent development of various methods of modulation such as PCM and PPM which exchange bandwidth for signal-to-noise ratio has intensified the interest in a general theory of communication. A basis for such a theory is contained in the important papers of Nyquist and Hartley on this subject. In the present paper we will extend the theory to include a number of new factors, in particular the effect of noise in the channel, and the savings possible due to the statistical structure of the original message and due to the nature of the final destination of the information.

The recent development of various methods of modulation such as PCM and PPM which exchange bandwidth for signal-to-noise ratio has intensified the interest in a general theory of communication. A basis for such a theory is contained in the important papers of Nyquist and Hartley on this subject. In the present paper we will extend the theory to include a number of new factors, in particular the effect of noise in the channel, and the savings possible due to the statistical structure of the original message and due to the nature of the final destination of the information.

Figure 3: First image is the original text image of size 302x410 pixels. Second image with 1031 data hidden in CWDD range [0, 1]. Third image shows the flipping pixel positions.

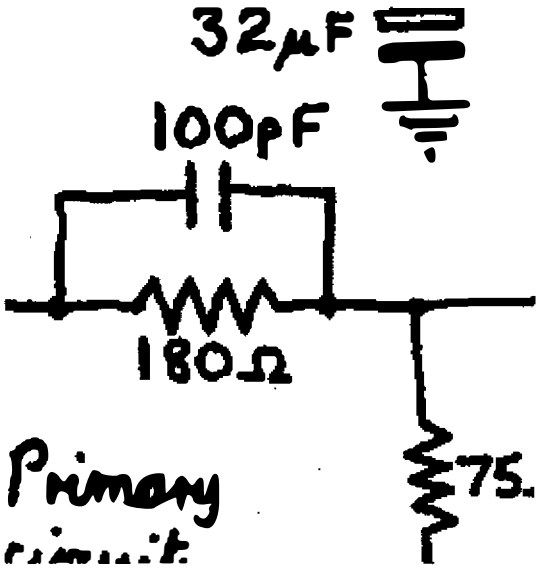

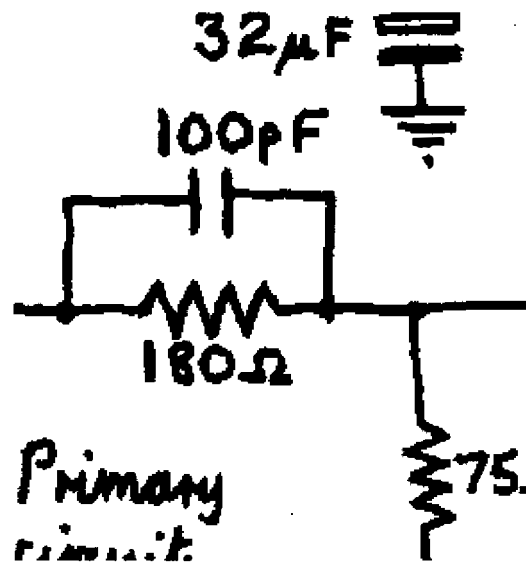

Figure 4: First image is the original drawing image of size 300x300 pixels. Second image with 455 bits hidden in CWDD range [0, 1]. Third image shows the flipping pixel positions.